

Making a Scale Drawing

Introduction

Objective → Students will create a detailed scale drawing.

Context → Students have used tools to measure length, solve proportions, and interpret scale drawings. They will continue to use ratio and proportion in the study of similar figures, percent, and probability.

NCTM Standards Focus

In this lesson, students will solve problems that involve creating a detailed scale drawing. They will consider how to choose an appropriate scale and will develop a method for positioning objects accurately in their drawings. Students will employ measurement skills and proportion as they gather and convert information to a visual representation that is useful to others.

Problem Solving Students will identify and solve practical problems as they work to make a scale drawing. They will explore positioning items in drawings by solving a simple problem involving a drawing of their desktop. Then they will extend their method to more complex situations.

Representation Students will represent information about the real world visually through a scale drawing. They will convert three-dimensional objects into two-dimensional representations and will reinforce their skills by interpreting each other's drawings.

Communication Students will work cooperatively to complete the different tasks involved in making their drawing. They will share their ideas on finding position and discuss ways in which scale drawings are used to communicate information.

TEACHING PLAN

Materials → Student pages A.29-30; rulers; grid paper (optional)

BEGIN THE LESSON with a brief discussion about scale drawings and how they are used.

- *What is a scale drawing?* (A drawing in which all the dimensions are reduced or enlarged proportionally.)
- *What are some common examples of scale drawings?* (Maps; blueprints; building or room plans; directions for assembling models, clothing patterns; etc.)
- *What does the scale of the drawing represent?* (The ratio between any actual length and the corresponding length in the drawing.)
- *If you know the scale of a drawing, how can you find an actual length from the length in the drawing, or an unknown length for a drawing from an actual*

A.25

[Source: [Connect to NCTM Standards Sixth Grade, p. 102-107](#), Creative Publications]

length? (Write and solve a proportion using the scale as one ratio.)

Present a few problems for students to solve to reinforce students' skills in setting up ratios and finding proportions. Discuss each solution and demonstrate the proportion method for solving the problem.

Suppose the scale of a drawing is 1 in. = 4 ft. The length of a wall on the drawing is 1H in. What is the actual length of the wall?

$$\left(\frac{1 \text{ in.}}{4} = \frac{1H \text{ in.}}{n}; 1n = 1H \times 4; n = 14 \text{ ft.} \right)$$

Suppose the scale of a map is 2 cm = 25 km. The actual distance between two towns is 80 km. What length would represent this distance on the map? Explain your work $\left(\frac{2 \text{ cm}}{25 \text{ km}} = \frac{n \text{ cm}}{80 \text{ km}} \right)$

Provide additional examples if students require more practice writing and solving the proportions.

Explain that when someone decides to make a scale drawing, they must first solve several problems. Perhaps the most important problem is deciding on the scale that will be used for the drawing. *What factors would you think about to choose a scale for a drawing? Explain.*

What Students Might Say

- The drawing needs to fit on the paper being used.
- The ratio should be easy to work with.
- The ratio should allow reasonably precise lengths to be represented and then determined by people using the drawing.
- The purpose and amount of detail of the drawing may be a factor – a drawing used to illustrate an apartment might not need to be as detailed and precise as a drawing used to construct the apartment.

DISTRIBUTE STUDENT PAGE A.29 and have students work in pairs. Ask them to clear a desktop and then place one or two simple objects such as a book, juice container, or a calculator on the desk. Explain that their assignment will be to create a scale drawing of their desktop that will fit in the given space on student page A.29.

The objects must be drawn to scale and positioned accurately on the drawing.

A.26

[Source: [Connect to NCTM Standards Sixth Grade](#), p. 102-107, Creative Publications]

Questions to help students organize their work will be found on the page.

Circulate among the groups as they work on their drawings and help students who are having difficulty with the positioning aspect. You may wish to have students that finish early offer assistance to other pairs.

Engage students in a discussion of their methods and point out similarities in the scales used by different groups.

- *What scale did you use?*
- *Did you try some scales that you decided not to use? Explain.*
- *Explain the method you used to position the objects accurately on your drawing.*

Have students compare classmates' desktops and drawings. Encourage students to describe and/or demonstrate their approaches. If no student mentions it, suggest that to position items, they should first measure the lengths at right angles from edges of the object to edges of the desk and convert the actual lengths to drawing lengths in the scale being used. Next, lightly pencil in guide lines until there are enough reference points to draw the scaled objects correctly positioned. Have the class decide which methods seemed the most efficient and let them practice by using objects on their desks.

Tell students that having dealt with some of the problems that are involved in making scale drawings for a simple situation, they will go on to deal with a much more challenging problem of creating a scale drawing of the classroom (or another location in the school).

Divide the students into larger groups of four to six and let them spend the remainder of the class time planning the work on this project. They will need to decide on the details they will include in their drawing, the scale they will use, the measurements needed, and the responsibility of each group member. The drawing should be made on a separate sheet of unlined or grid paper; the largest size sheet available should be provided. You may wish to set up a schedule for different groups to take their measurements, and allot class time for completion and discussion of the drawings.

Extension

Encourage students to bring in maps or scale drawings and ask them to write one or two problems based on the materials they are using. Students can trade problems with a classmate to solve.

A.27

[Source: [Connect to NCTM Standards Sixth Grade](#), p. 102-107, Creative Publications]

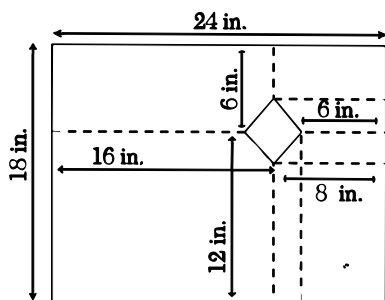

As an interesting challenge, show students a map of their state from which the scale has been deleted. Supply the actual distances between one or more pairs of major cities. Have students use the information and their own measurements to determine the scale that was used and then compare their results with the actual scale.

Student Pages

Student page A.29 provides questions to guide students as they work on the classroom desktop activity, plus space for their scale drawings. Student page A.30 presents detailed information about a room and its furnishings. This information provides an opportunity for additional practice with scale computations. Students might then use their scaled dimensions to design the room of their choice.

Assessment

As students reviewed their knowledge of scale drawings, you were able to assess their understanding of the concept and their facility with ratios and proportions. Students' insights into a problem-solving situation could be evaluated as they planned and created their drawings. As they explained their ideas about the class activity and their computational methods, you were able to judge their proficiency in carrying out the measuring, converting, and positioning. When students worked cooperatively on the larger project, you could observe their ability to structure a complex assignment. Their final scale drawing provided an opportunity for overall assessment of their proficiency with this topic.

NCTM Standards Summary

In this activity-based lesson, students identified and solved problems related to making an accurate scale drawing. By first working on a simple problem, students gained experience choosing a scale and developed their own methods for representing objects. In sharing their methods, students communicated useful information to others and affirmed their own understanding of the processes involved. Communication also reinforced understanding of the computational skills involved in creating and interpreting scale drawings.

Answers

Page A.29

Answers will vary.

Page A.30

Scale dimensions

Living room: 5.5 in. x 3.25 in.

Windows: 0.55 in.

Entry: 1 in.

Sofa: 1.5 in. x 0.5 in.

Easy chairs: 0.6 in. x 0.45 in.

Rocking chair: 0.35 in. x 0.57 in.

Table: 0.7 in x 0.65 in.

Plant stand: 0.35 in. x 0.3 in.

Entertainment: 0.9 in. x 0.4 in.

A.28

[Source: [Connect to NCTM Standards Sixth Grade, p. 102-107](#), Creative Publications]

Making a Scale Drawing

Place 2 or 3 items on your desktop. Answer the questions about your arrangement and then make a scale drawing of your desktop in the space below. Use the back of this page for calculations and notes.

- ❶ Record the actual length of your desk.
- ❷ Record the actual width.
- ❸ Name the object(s) you will show on your drawing. Give the actual dimensions of each object.
- ❹ Write the scale you will use for your drawing. Explain how you chose this scale.
- ❺ Record the length your desk will be in your scale drawing. Show how you found this measurement.
- ❻ Record the width your desk will be using in your scale drawing. Show how you found this measurement.
- ❼ Explain the method you used to determine the position of the objects in your drawing.

A.29

[Source: [Connect to NCTM Standards Sixth Grade, p. 102-107](#), Creative Publications]

Making a Scale Drawing

Use the information provided to create a scale drawing.

The Benson's have the following information about their new living room:

- The room is 27.5 feet long and 16.25 feet wide.
- Along the length of the room are two equally spaced windows. Each window is 33 inches wide.
- There is a 5-foot entry space along the side of the room facing the windows.

The Benson's would like to put the following furniture in their room:

- A sofa that is 90 inches long and 30 inches deep
- Two easy chairs that are each 36 inches wide and 27 inches deep
- A rocking chair that is 21 inches wide and 34 inches deep
- A table that is 42 inches long and 39 inches deep
- A plant stand that is 21 inches wide and 18 inches deep
- An entertainment unit that is 54 inches wide and 24 inches deep

Give the scale-drawing measurements of the room and each piece of furniture. Show a possible arrangement of the furniture in your scale drawing.

Scale: 1 inch = 5 feet

living room _____	sofa _____	table _____
windows _____	easy chair _____	stand _____
entry _____	rocking chair _____	entertainment unit _____

A.30

[Source: [Connect to NCTM Standards Sixth Grade, p. 102-107](#), Creative Publications]